

ELECTRONIC HARDWARE

**HEX THREADED, FEMALE STANDOFFS**

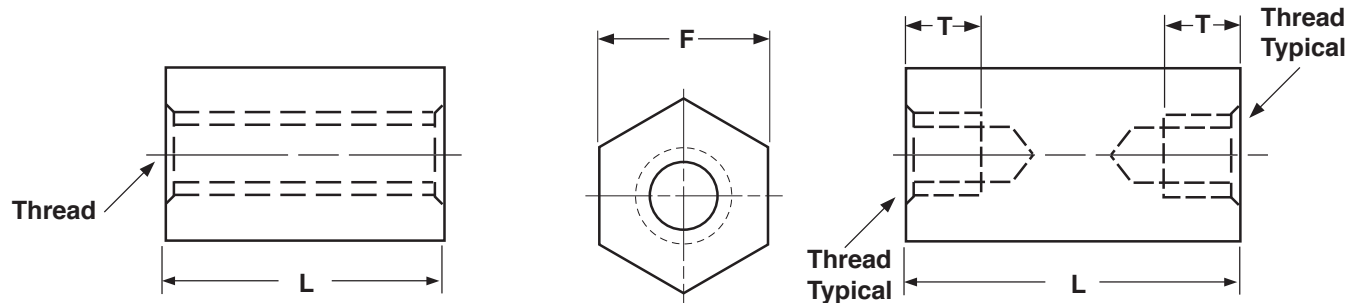

HEXAGON STANDOFFS						
F	Thread Size	T	F	Thread Size	T	
Width Across the Flats (± 1/64)		Thread Depth			Width Across the Flats (± 1/64)	Thread Depth
		Min				Min
1/8	2-56	3/16	3/8	6-32	3/8	
3/16	2-56	3/16	3/8	8-32	7/16	
3/16	4-40	1/4	3/8	10-32	1/2	
1/4	2-56	3/16	1/2	6-32	3/8	
1/4	4-40	1/4	1/2	8-32	7/16	
1/4	6-32	3/8	1/2	10-32	1/2	
1/4	8-32	7/16	1/2	1/4-20	5/8	
1/4	10-32	1/2	5/8	8-32	7/16	
5/16	4-40	1/4	5/8	10-32	1/2	
5/16	6-32	3/8	5/8	1/4-20	5/8	
5/16	8-32	7/16	5/8	5/16-18	5/8	
5/16	10-32	1/2	5/8	3/8-16	5/8	
Tolerance on Length (up to 4 in.)		Nylon parts: ±.015		All other materials: ±.005		

<b>Description</b>	A hexagonal, mechanical device which has a partial or complete internal thread, used to hold two components at a given distance from each other.
<b>Applications/Advantages</b>	Standoffs are usually chosen over spacers when longer sizes are required. Hex standoffs can be installed with a nutsetter or other wrenching device. Aluminum is popular for its light weight/ strength compromise. It is non-magnetic, performs well in severe temperatures, and has insulating properties. Nylon is a good insulator and has a surface smoothness which will not fray the insulation of wires that rub against it. Its threads will withstand torque without stripping. Brass is used in making high-quality standoffs. It is conductive, resists corrosion, and is non-magnetic. It is costlier and heavier than aluminum and is usually plated zinc or nickel. Stainless has the advantages of brass but has superior resistance to corrosion and chemical fumes. Steel is used in applications requiring greater strength, but it is heavier than aluminum and does not resist corrosion like aluminum or brass.
<b>Material</b>	<p><b>Aluminum:</b> 2011 Aluminum (Copper: 5.0-6.0%; Silicon: 0.4% maximum; Iron: 0.7% maximum; Zinc: 0.3% maximum; Bismuth: 0.2-0.6%; Lead: 0.2-0.6%)</p> <p><b>Nylon:</b> Nylon 6/6</p> <p><b>Brass:</b> C36000 Brass (Copper: 60.00-63.00%; Lead: 2.50-3.70%; Iron: .35% maximum)</p> <p><b>Stainless:</b> 303 stainless, passivated to ASTM A 380</p> <p><b>Steel:</b> 12L14 Steel-Leaded Grade A (Carbon: .15% maximum; Manganese: .85-1.15%; Phosphorus: .04-.09%; Sulphur: .26-.35%)</p>

This page prints with a watermark