

SELF- TAPPING SCREWS

**HEAD DIMENSIONS** Serrated Pan Phillips & Round Washer 6-lobe

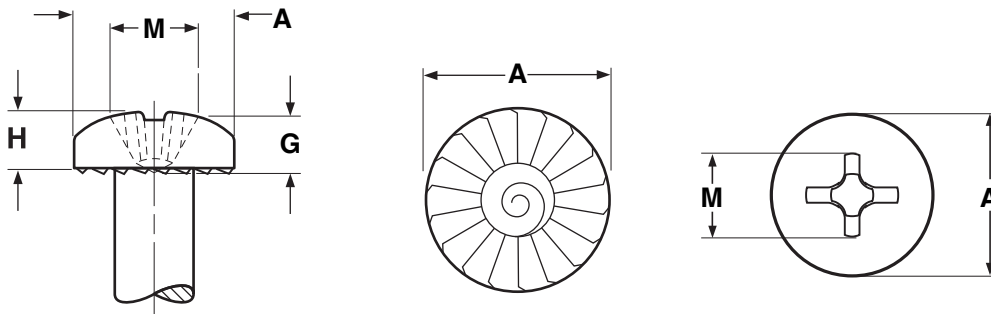

SERRATED PAN PHILLIPS FOR TAPPING SCREWS								
Nominal Size	A		H		M	G		Recess Size
	Head Diameter		Head Height		Recess Diameter	Recess Penetrating Gaging Depth		
	Max	Min	Max	Min	Ref	Min	Max	
4	.219	.205	.080	.070	.115	.071	.053	1
6	.270	.256	.097	.087	.159	.080	.055	2
8	.322	.306	.115	.105	.176	.097	.071	2
10	.373	.357	.133	.122	.192	.113	.089	2
1/4	.492	.473	.175	.162	.274	.144	.118	3

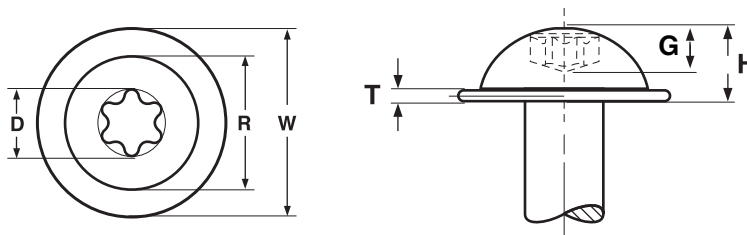

SIX-LOBE RECESS ROUND WASHER HEAD										ASME B18.6.3-2013	
Nominal Screw Size	W		T	R	H		D	G		(Fallaway) Max Penetration	Driver Size
	Washer Outside Diameter		Washer Thickness	Head Outside Diameter	Overall Head Height		Recess Diameter	Gauge Penetration			
	Max	Min	Ref	Ref	Max	Min	Ref	Max	Min		
8	.380	.358	.040	.259	.113	.101	.155	.065	.050	.031	T20

This page prints with a watermark