

METRIC FASTENERS

THREAD FORMING SCREWS **Type-PT® Alternative Round Washer Six-Lobe**

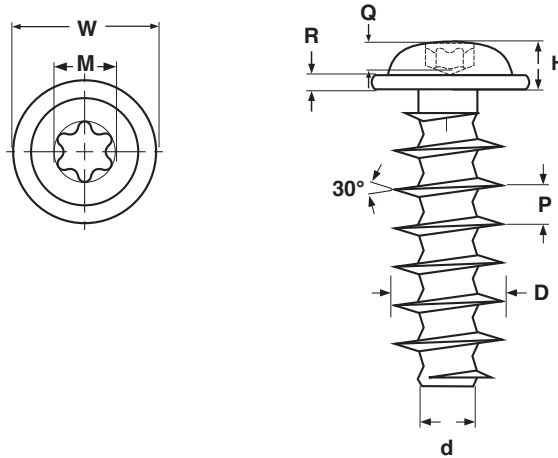

METRIC - TYPE PT®-ALTERNATIVE THREAD FORMING SCREWS, ROUND WASHER 6-LOBE												
Screw Size	P	D	d	W		R		H		M	Q	Drive Size
	Thread Dimensions			Head Dimensions					Recess Dimensions			
	Thread Pitch	External Diam.	Thread Core	Washer Diameter		Washer Thickness		Height		Diameter	Gauge Penetration	
				Min	Ref	Max	Min	Max	Min			
M1.6	0.67	1.6	0.95	3.6	3.12	0.60	0.40	1.32	1.075	1.47	0.40	T5
M2	0.89	2.0	1.15	4.0	3.7	0.60	0.40	1.3	1.175	1.75	0.50	T6
M2.2	0.98	2.20	1.25	4.5	4.2	0.70	0.50	1.4	1.275	1.75	0.70	T6
M2.5	1.12	2.5	1.40	5.0	4.7	0.70	0.50	1.5	1.375	2.39	0.75	T8
M3	1.34	3.00	1.66	6.0	5.7	0.80	0.60	2.1	1.975	2.80	1.05	T10
M3.5	1.57	3.50	1.91	7.0	6.7	0.90	0.70	2.4	2.275	2.80	1.15	T10
M4	1.79	4.00	2.17	8.0	7.7	1.00	0.80	2.6	2.475	3.95	1.25	T20
M5	2.24	5.00	2.68	10.0	9.7	1.20	1.00	3.3	3.175	3.95	1.40	T20
Tolerance on Length				3 ~ 6mm: ± 0.30 mm					7 ~ 10mm: ± 0.40 mm			
				11 ~ 30mm: ± 0.50 mm					31 ~ 80mm: ±0.65 mm			

Description	A spaced thread fastener with a dome-shaped head and an integrally-formed washer; a recess that accommodates a 6-lobed driver; and a flat bearing surface that is 90° to the screw's shank. When compared to a Plastite®-alternative thread rolling screw, the PT®-alternative threads are wider and have a sharper angle. Furthermore, the core of the shank has a reduced diameter between each consecutive set of threads. The point opposite the head is blunt.	
Applications/ Advantages	Designed to form its own thread in thermoplastic materials. The 30° thread angle reduces the outward expansion of the material being displaced. The recessed design of the thread root enables more material to flow into the area between threads. The depth of the thread pattern increases the fastener's load carrying properties while resisting vibrations, thus resisting loosening.	
Material	<i>Steel</i>	<i>Stainless</i>
	Diameter M3 & smaller: Case-Hardened C1022 Steel Diameters M3.5 and larger: Through-hardened C1022 Steel	A2 Stainless
Core Hardness	HV 270 - 390	-
Surface Hardness	HV 450 min.	-

Type PT® is a registered trademark of EJOT Verbindungstechnik GmbH & Co. KG. This page prints with a watermark